

128 Beams Light Curtain Elevator Door Detector E(2 in 1,Mitsubishi model)



Technical Data:

Model	E
Number of diodes	64
Maximum beams	128 beams
Highest Detecting height	1841 mm
Lowest Detecting height	20 mm
Profile dimension	2000mm (height) × 20mm (thickness) × 55mm (width)
Detecting distance	0 - 3000mm
Vertical tolerance	+/- 10mm,7°
Horizontal tolerance	+/- 3mm,5°
Response Time (Relay)	57.5ms
Cable reliability	30 million door movements
Power consumption	≤4W or 100Ma @ DC24V
Voice reminder	Buzzer In RX,after continuous detection for 15s,buzzer On
Light immunity	≥100000 LUX
EMC compliance	Emission to EN12015, Immunity to EN12016
Operating temperature range	-20℃ ~+65℃
IP Rating	IP54(TX,RX)
Vibration test	Random vibration 20 to 500Hz for 4hrs per axis(X,Y,Z) Sinusoidal vibration 30Hz for 30mins per axis(X,Y,Z)

Power Supply:

Model	Voltage Range
AC220V	Input voltage 220V±15%

Installation drawing for the centre opening:

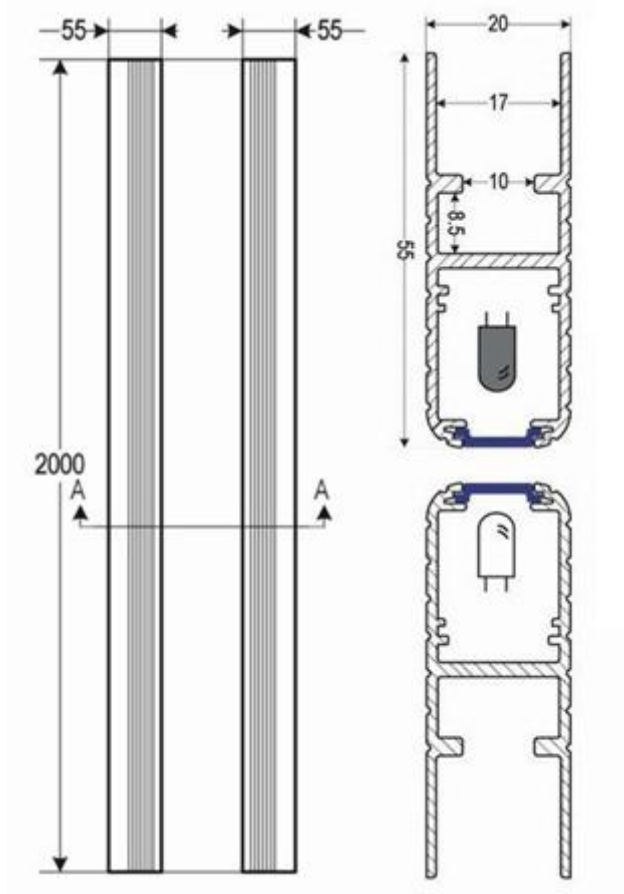

Mechanical linkage:

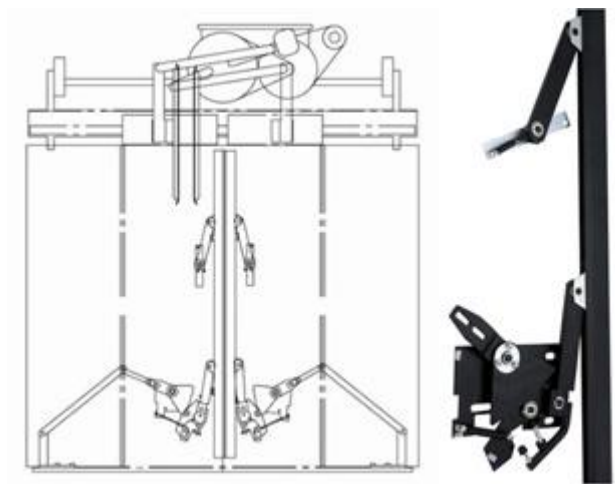

Please purchase matched mechanical linkage for installation

Installation drawing for the side opening:

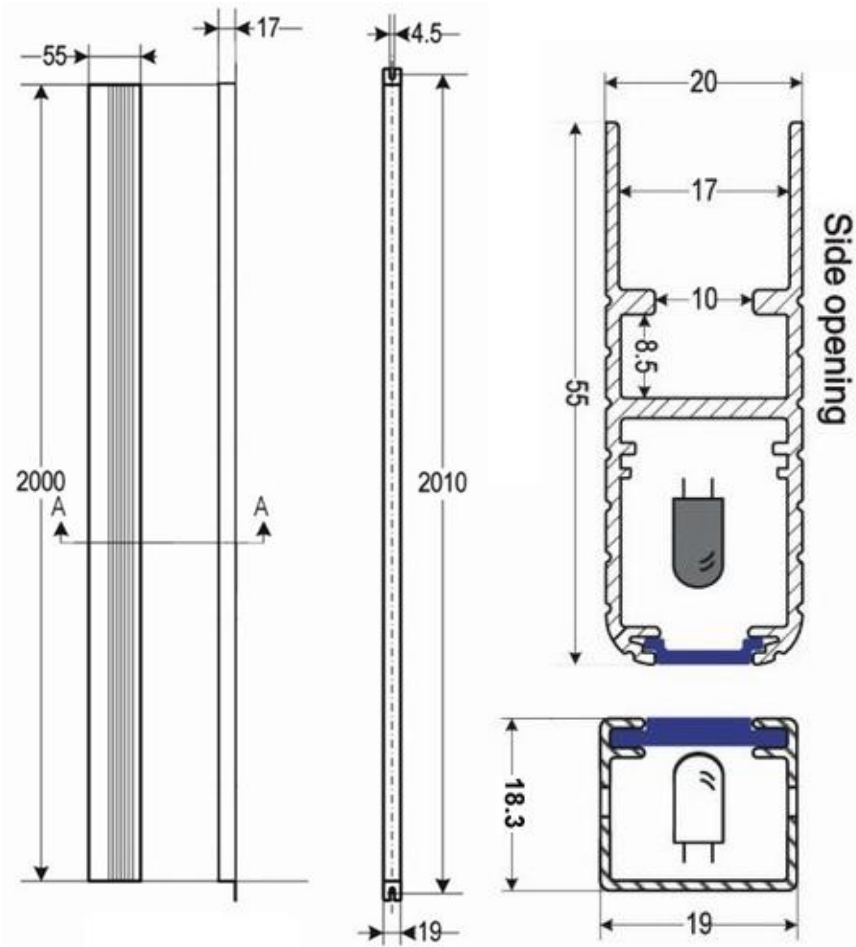

Packing List:

Item	Quantity
Control Box (Power Supply Unit)	1 PCS
Transmitter	1 PCS
Receiver	1 PCS
Flexible Cable	2 PCS
User Manual	1 PCS
Mounting Accessories	1 SET
Note:standard full set is not including mechanical linkage	