

Electromagnetic Rope Gripper OX-250B

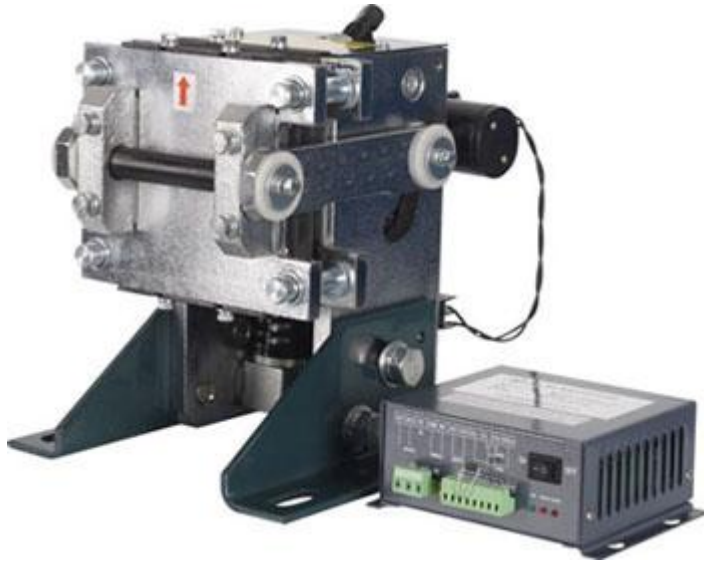

Installation Dimension: OX-250B-A

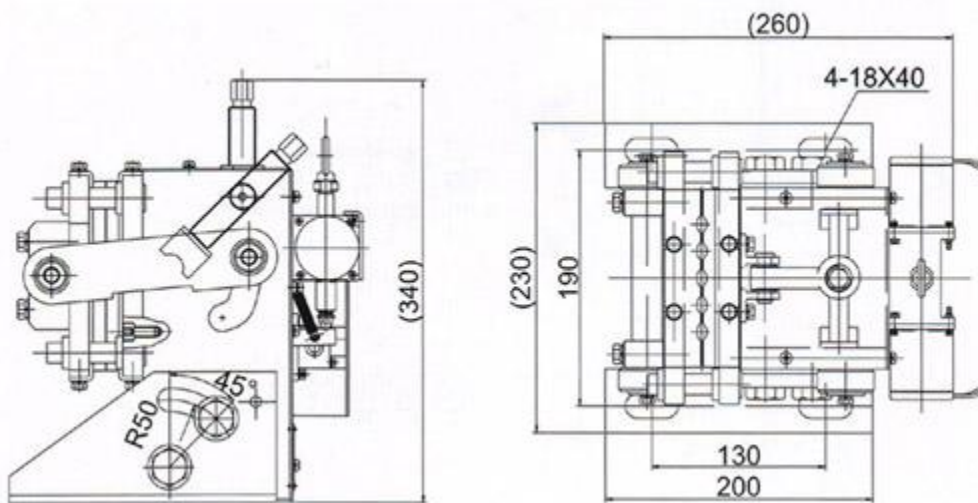

Specification:

| | |
|------------------|--|
| Rated Speed | a)1:1 $V \leq 2.5\text{m/s}$ b)2:1 $V \leq 1.25\text{m/s}$ |
| Rated Load Range | a)1:1 $Q = 320\text{kg} \sim 1600\text{kg}$ b)2:1 $Q = 640\text{kg} \sim 3000\text{kg}$ |
| Total Weight | a)1:1 992kg~5425kg b)2:1 1984kg~10850kg |

Installation Dimension:
OX-250B-B

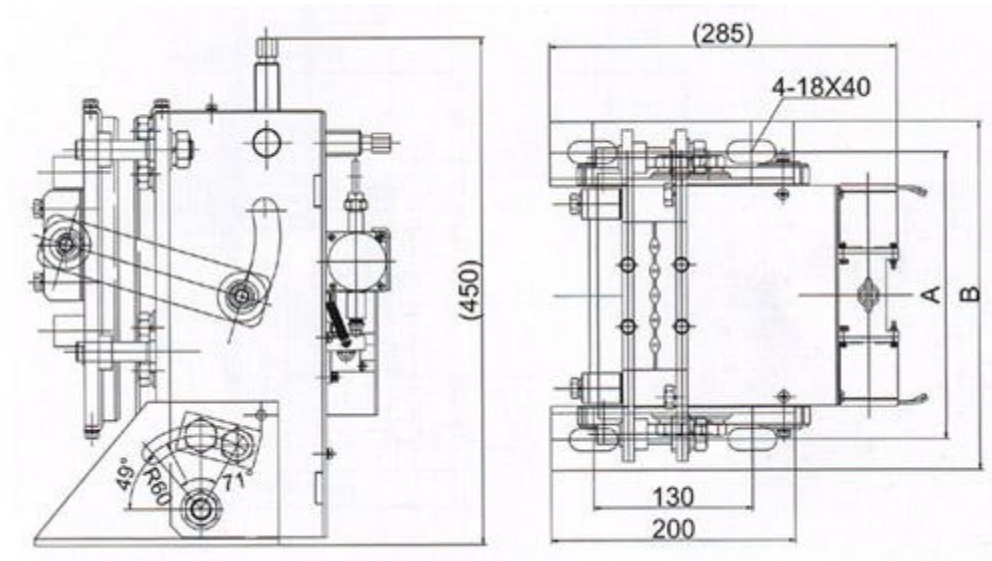

Specification:

| Item | A | B | Wire Rope Diameter | Number of Groove | Traction Sheave Groove Specification |
|------|-----|-----|--------------------|------------------|--------------------------------------|
| 01 | 235 | 285 | ≤16MM | ≤5 | ≤25MM |
| 02 | 270 | 320 | ≤16MM | 6~8 | ≤25MM |

| | |
|------------------|---|
| Rated Speed | a)2:1 V≤0.5m/s b)4:1 V≤0.25m/s |
| Rated Load Range | a)2:1 Q=3000kg~5000kg b)4:1 Q=6000kg~10000kg |
| Total Weight | a)2:1 5590kg~11500kg b)4:1 11180kg~23000kg |